



Getting a Landlord To Make Repairs

A tenant has the right to live in a home that is in reasonable repair, meets local housing codes and is reasonably energy efficient. The landlord has the responsibility to make sure your home is fit to live in. If your landlord will not make repairs, there are things you can do to make the landlord fix the problems.

If it is an emergency, call your legal aid office right away. Emergencies are things like no power, no heat, no stove or oven, no working plumbing, no hot water, or an intent-to-condemn notice.

If it is not an emergency, do these things:

- Fill out the repair list at the end of this fact sheet and mail it to your landlord. Keep a copy. It is best to send a list like this or a letter but texts and emails work too. You need to print them out with date and time stamp.
- If your city has housing inspectors, call them. When they come, show them your list so that they do not miss anything. Ask for a copy of their report.

In Minneapolis, call 311. In St. Paul, call (651) 266-8989. In other parts of the state you can call First Call for Help at 211, or 1- (800) 543-7709 to see if your city has a housing inspector.

Housing inspectors may find problems that you missed. If the problems are bad enough, they can condemn the building if repairs aren't made. If problems are not emergencies, inspectors usually give landlords 30 days to fix them.

A landlord cannot evict you for asking for repairs or calling a housing inspector. But a landlord can try to evict you if you don't pay rent because of repair problems. If you have part of your rent and a landlord tries to evict you only because you asked for repairs, you can ask the court to dismiss the eviction and "expunge" it, which means erasing it from public records. See our fact sheet [Evictions](#).

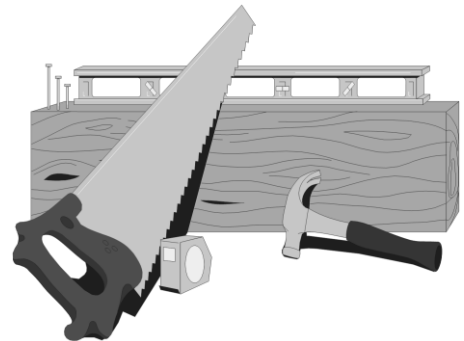

- If the landlord still does not make the repairs after you write a letter or call the inspector, file a Rent Escrow action. This means you pay your rent to the court to start a case against the landlord. The case is to get a court to order repairs. You can also use the case to make your landlord follow the things in your lease if they have been violated. You can file one if:
 - It has been 14 days since you sent the landlord a letter about repairs and/or other lease violations by your landlord **or**
 - A deadline given by housing inspectors has passed or the housing inspector gave the landlord too much time to make repairs.

If you have a low income, call your legal aid office. You can find yours at: www.lawhelpmn.org/resource/legal-aid-offices. They can represent you, refer you to another agency, or give you advice. If you can't get a lawyer, you can do it yourself.

Until you file your Rent Escrow action, pay your rent to the landlord as soon as the rent is due. If you do not pay, your landlord can file an eviction against you. You may have defenses because of the repair problems, but it is better and safer to use a Rent Escrow action than to defend an eviction.

- To file a Rent Escrow action, go to the county courthouse. Take with you:

1. a Rent Escrow Affidavit (the form attached)
2. a copy of the inspection orders or your letter to the landlord, and
3. **all the rent due** (cash or certified check). You don't need to wait until your rent is due to file a Rent Escrow. But you must pay **all** the rent into court when it is due.



If you don't pay all of the unpaid rent into court when you file a Rent Escrow, your landlord could counterclaim to evict you.

There is a filing fee. If you have a low income, fill out a court fee waiver form (IFP) to ask the court to let you skip paying the fee. The court has these forms or you can [create one online](http://www.LawHelpMN.org/resource/form-helper) using a step-by-step interview at www.LawHelpMN.org/resource/form-helper.

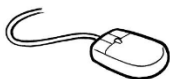

- Click on *Debts, Fees and Deposits*
- Click on *Court Fee Waiver (IFP)*

Bring proof of your low income, like pay stubs, or proof of government assistance.

- The clerk will set a hearing for you within 10-14 days. Bring all your evidence to the hearing.
 - Photos that show the problems are very helpful. Label and date them for the court.
 - If an inspector has been out, go to the inspections office and get a **certified** copy of the Inspection Report. If the inspector knows more than is in the report, you can “subpoena” (make) them come to court. Ask the court clerk how to do this.
 - You can also bring other witnesses, like a neighbor who has seen the repair problems.

For each repair problem, show the court:

- How long it’s been a problem.
 - How long the landlord knew about it.
 - How the problem has affected you and made your life worse. Give details!
- You can ask the court to:
 - Order repairs.
 - Reduce your rent until the repairs are done.
 - Give you back rent money for the months you lived there with the repair problems.
 - Let you get the repairs made and deduct the cost from your rent.



Here is an example:

It is now June. You moved in January 1. The plumbing was bad when you moved in. You told your landlord in writing about the bad plumbing right away. The roof has leaked since March, and you told the landlord in writing as soon as it started to leak.

If you have not paid June rent, you can start a Rent Escrow case by putting the unpaid June rent into court along with the attached Rent Escrow affidavit and a copy of your letters from January and March. You can ask for some money off the rent for January and February because of the bad plumbing and a larger amount off for March, April, May and June, because of the second problem, the leaky roof.

So, out of the money you paid into court, some of it should go back to you because of the repair problems that were not fixed. Also, your future rent should be reduced until the landlord makes all of the repairs that the court orders.

It is important to note that the judge has a lot of power to decide how much of a rent reduction you should get. Different judges give different values to repair issues so the amount of rent reduction can be very different depending on who decides your case or where you live.

Remember: The main point of a rent escrow case is to get repairs made, not to get rent back. This is why it is important for you to show how each problem affected you and made your life worse in the rental home. Proving how each problem made your life worse can help convince a judge to give you a rent reduction along with ordering repairs.

Is there anything else I can do?

If you don't file a Rent Escrow, you can sue in Conciliation Court to get rent money back. You can do this while you live there or after you move out.

In Conciliation Court, you can't ask for repairs to be made – just for money damages. You do not need a lawyer. For evidence, it helps to have things like letters, inspection reports, and photos. See our fact sheet, [Conciliation Court](#).



Find more fact sheets at www.lawhelpmn.org/LASMfactsheets

Find your local legal aid office at www.lawhelpmn.org/resource/legal-aid-offices

Fact Sheets are legal information NOT legal advice. See a lawyer for advice.

Don't use this fact sheet if it is more than 1 year old. Ask us for updates, a fact sheet list, or alternate formats.

© 2018 Minnesota Legal Services Coalition. This document may be reproduced and used for non-commercial personal and educational purposes only. All other rights reserved. This notice must remain on all copies. Reproduction, distribution, and use for commercial purposes are strictly prohibited.

TENANT'S REPAIR LIST – Request for Repairs

Dear _____ Date: _____

Please make the following repairs within the next 14 days.

√	PROBLEM	WHEN IT STARTED	DESCRIPTION
INFESTATIONS			
	Mice		
	Cockroaches		
	Bed bugs		
	Other		
ELECTRICAL			
	No/ broken smoke detector		
	Exposed Wiring		
	Short Circuits		
	No cover plates on outlets		
	Other		
PLUMBING			
	No hot water		
	Clogged pipes/toilet		
	Bad water pressure		
	Dripping faucets		
	Leaks		
	Other		
WINDOWS			
	Missing/torn screens		
	Missing/torn storm windows		
	Broken/cracked glass		
	Missing/ broken locks		
	Other		
DOORS			
	No deadbolt locks		
	Broken locks		
	Missing/broken door knobs		
	Other		

√	PROBLEM	WHEN IT STARTED	DESCRIPTION
	WALLS / CEILINGS/ FLOORS		
	Chipped / flaking paint		
	Holes or cracks in walls		
	Leaky roof or ceiling		
	Holes in carpet		
	Missing/broken tiles or linoleum		
	Other		
	FURNACE		
	Not enough heat		
	Gas leaks		
	Other		
	APPLIANCES		
	Broken stove/oven		
	Broken refrigerator		
	Other		
	SECURITY / PRIVACY		
	Illegal entries by landlord		
	Disturbance by other tenants		
	Break-ins, vandalism		
	Other		
	OTHER AREAS		
	Bare patches in yard		
	Trash from previous tenant		
	Problem with garage		
	Leaky basement		
	Pay utility bills		
	Other		

Tenant's Name: _____

Tenant's Address _____

Tenant's Signature _____

STATE OF MINNESOTA

COUNTY OF _____ JUDICIAL DISTRICT _____

Plaintiff (tenant)

**RENT ESCROW
AFFIDAVIT**

vs.

FILE NO:

Defendant (Landlord)

Plaintiff states under oath:

1) My address is _____

2) My landlord's name is _____

3) My landlord's address is _____

4) The monthly rent is \$ _____

- 5) I sent the landlord a written notice describing the repair problems or violations of the lease. The landlord did not fix them within 14 days. A copy of my letter or other written communication is attached.
- and / or
- An inspector ordered the landlord to make repairs. The inspector's deadline has passed, and the landlord has not made all the repairs. A copy of the inspector's orders is attached.

6) As of today, the amount of rent that I owe is \$ _____ I am depositing that amount with the court.

7) My best estimate is that it would cost \$ _____ for the landlord to make all the repairs.

8) The landlord has known about these repair problems since approximately the following date or dates _____

9) Since these repair problems have existed, my apartment has not been worth the amount of rent I pay. It has only been worth \$ _____ per month.

- 10) I respectfully ask the court to issue an order including the following:
 - a. Order the landlord to make all of the repairs right away.

- b. Reduce my rent to \$ _____ per month until the month after all of the repairs are completed. For any repairs that the landlord does not complete by the Court's deadline, authorize me to pay for the repairs myself and deduct the payments from future rent.
- c. Of the money I deposited with the court, order that \$ _____ be returned to me, for the rent that I have paid while the landlord did not make the repairs.
- d. If I am entitled to more rent money back for the repair problems in the past months, enter a judgment against the landlord for \$ _____ and authorize me to collect the judgment by taking it out of future months' rent.
- e. If I have used an attorney, enter a judgment in my favor for reasonable attorney fees. Authorize me to collect the judgment by taking it out of future months' rent.
- f. Set a follow-up hearing to make sure the landlord has made the repairs ordered.
- g. Other: _____

11) To the best of my knowledge, I am not filing this case for an improper reason, such as harassment or delay; my claims are supported by the law, and there is evidence for them. I know that I can be fined or sanctioned by the court if this statement is false.

I declare under penalty of perjury that everything I have stated in this document is true and correct.

Dated: _____

Signature

Name: _____

Address: _____

City, State, Zip: _____

Phone: _____

E-mail: _____

For the court to fill out

Total rent deposited: \$ _____ + \$16.00 filing fee = \$ _____ total paid.

Set for _____ at ____ M, in _____ Notice sent _____

Continued to _____ at ____ M, in _____ Notice sent _____