



Mus Cuag Koj Tus Tswv Tsev Kom Xyuas Kev Kho

Getting a Landlord to Make Repairs

Tib neeg xauj tsev muab txoj cai nyob vaj tsev ua tsim nyog kho lawm, ua raws li hauv zos cov kev cai vaj tsev thiab tsim nyog ua tau hluav taws xob khiav zoo. Lub luag hauj lwm nyob ntawm tub tswv tsev yuav tsum paub tseeb tias lub tsev tsim nyog nyob. Yog tus tswv tsev yuav tsis kho, yeev muaj tej yam uas koj siv tau los pab ua tus tswv tsev los kho cov teeb meem ntawd.

Yog thaum muaj teeb meem loj, hu koom huam Legal Aid tam sim. Tej yam ua yog thaum muaj teeb meem loj yog li tsis muab fai fab, tsis muab qhov kub, cov kav dej tsis ua hauj lwm, tsis muab dej kub, los puab yog daim ntawv ceeb toom (Intent-to-Condemn).

Yog tsis yog teeb meem loj, ua tau li cov yuav qhia no:

- Sau tawm daim ntawv teev ua nyob tom qab daim ntawv qhia no ces xa rau koj tub tswv tsev. Ua ib daim ntawv luam tseg.
- Yog koj lub xos muab neeg kuaj xyuas vaj tsev (Housing Inspector), hu lawv. Thaum lawv tuaj, muaj koj daim ntawv teev rau lawv saib li ntawd nws twb tsis kuaj dhau dab tsi. Nug lawv luam lawv daim ntawv kuaj xyuas rau koj khw tseg.

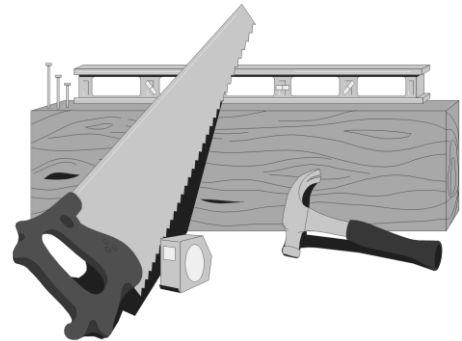

Nyob rau hauv Minneapolis, hu xob tooj 311. Nyob rau hauv St. Paul, hu (651)256-8989. Nyob rau hauv lwm xos hu lus koom haub First Call los pab ntawm 211, los puab yog 1-(800) 543-7709 es xyuas seb koj lub xos puab muaj neeg kuaj xyuas vaj tsev.

Neeg kuaj xyuas vaj tsev tej zaum nrhiav tau tej yam ua koj xyuas tsis tau txog. Yog cov teeb meem phem txaus, lawv rau txim tau rau lub tsev yog tsis tau muab kho. Yog tej teeb meem tsis loj, tus neeg kuaj xyuas vaj tsev mas muaj 30 hnub rau tus tswv tsev los kho.

Yog koj nug kom kho tsev, ib tus tswv tsev tsis muaj kev cai ntiab koj tawm. Tab sis yog koj tsis them nqi tsev vim hais tias tus tswv tsev tsis kho vaj tsev, nws muaj cai sim ntiab koj tawm. Yog ib tus tswv tsev ntiab koj tawm vim hais tias koj nug nws kho tsev, koj muaj cai nug lub tsev hais plaub muab nws cov ntaub ntawv ntiab tawm tso tseg thiab “lww” (“Expunge”), txhais tau hais tias muab lww tawm koj cov ntaub ntawv pej xeem. Saib lwm yam ntaub ntawv qhia txog tej yam no [Evictions](#). (lus Askiv xwb)

- Yog koj xa tsab ntawv los puab yog hu tus neeg kuaj xyuas tsev es tus tswv tsev tseem tsis kam kho, sau tawm ntaub ntawv tiv thaiv nqi xauj tsev (Rent Escrow). Qhov no txhais tau hais tias koj them koj cov nqi xauj tsev rau ntawm tsev hais plaub rau lawv ua ntaub ntawv foob tus tswv tsev. Cov ntaub ntawv foob yog ua rau lub tsev hais plaub yuam tus tswv tsev los kho vaj tsev. Yog koj tus tswv tsev tsis tau ua raws li nej daim ntawv xauj tsev (lease), koj yeev siv tau cov ntaub ntawv no los pab hais tus tswv tsev. Koj ua tau ntaub ntawv tiv thaiv nqi xauj tsev li:
 - Koj xa ib tsab ntawv qhia los puab yog tus tswv tsev tsis tau ua raws li daim ntawv xauj tsev tau 14 nhub, **los puab yog**
 - Qhov sijhawm tus neeg kuaj xyuas tsev muab tau dhau lawm.

Yog koj qhov nyiaj khwv tau los tsawg tsawg, hu koj lub koom haum Legal Aid. Koj nrhiav tau ntawm: www.lawhelpmn.org/resource/legal-aid-offices. Lawv pab sawv cev rau koj, pab nrhiav ib lub koom haum txawv los pab, los puab yog pab qhia kev cai. Yog koj nrhiav tsis tau ib tus kws hais plaub, koj yeev ua tau rau koj tus kheej thiab.

Ua ntej koj sau tawm daim ntaub ntawv tiv thaiv nqi xauj tsev (Rent Escrow), them koj li nqi xauj tsev rau koj tus tswv tsev thaum txog hnuv tas caij. Yog koj tsis them, koj tus tswv tsev muaj cai ua ntaub ntawv ntiab koj tawm. Koj yeev muaj kev tiv thaiv koj tus kheej, tab sis yog koj ua daim ntaub ntawv tiv thaiv nqi xauj tsev ces yuav zoo zog.

- Mus rau tim lub tsev hais plaub ntawm zos thaum yuav sau tawm daim ntaub ntawv tiv thaiv nqi xauj tsev. Coj nrog koj:

1. Daim ntawv ua ntaub ntawv tiv thaiv nqi xauj tsev (Rent Escrow Affidavit) nyob tom qab daim ntawv qhia no
2. Daim ntawv teev tus neeg kuaj xyuas tsev muaj los puab yog tsab ntawv koj xa rau tus tswv tsev, thiab
3. **Tag nrho cov nqi xauj tsev tas caij** (them tau rau nyiaj ntsuab los puab yog daim tshev [certified check]). Koj tsis thaj tos txog sijhawm them nqi es mas mus ua daim ntaub ntawv tiv thaiv nqi xauj tsev. Tab sis koj yuav tsum them **tag nrho** cov nqi xauj tsev los rau lub tsev hais plaub thaum txog sijhawm them nqi.



Yog koj tsis them tag nrho cov nqi xauj tsev ua tsis tau tau them tswv tsev thaum koj mus ua daim ntaub ntawv tiv thaiv nqi xauj tsev, koj tus tswv tsev muaj cai mus sau tawm daim ntaub ntawv ntiab koj tawm.

Yeev muaj nqi los ua cov ntaub ntawv no. Yog koj qhov nyiaj khwv tau los tsis tau ntau, koj yeev ua tau daim ntaub ntawv thov ua pub dawb (IFP form) es tsis them cov nqi ntawd. Mus coj tau ntaub ntawv tim tsev hais plaub los puab yog koj [ua tau online](http://www.LawHelpMN.org/formhelper) los pab qhia txog kev sib tham tom

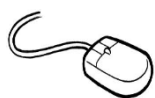

www.LawHelpMN.org/formhelper. (lus Askiv xwb)

- Xaiv cov lus *Debts, Fees and Deposits*
- Ces xaiv *Court Fee Waiver (IFP)* thiab

Coj koj cov ntaub ntawv pov thawj nyiaj khwv tau tswag, li tws nyiaj tshev, los puab yog daim ntaub ntawv pov thawj thov nyiaj.

- Tus pab tsev hais plaub yuav hu teem caij nrog koj 10 mus txog 14 hnuv tom qab koj ua sau tawm ntaub ntawv. Coj tag nrho koj cov ntaub ntawv pov thawj thaum mus sim hais plaub.
 - Cov duab ua qhia tau cov teeb meem yeev pab tau ntau. Sau hnuv thiab qhov teeb meem yog dab tsi pub rau tsev hais plaub.
 - Yog tus neeg kuaj xyuas tsev tsis nyob lawm, mus tom nws chaw ua hauj lwm es mus nqa ib **daim ntawv pov thawj** ua tus neeg kuaj xyuas tsev (Inspection Report). Yog tus neeg kuaj xyuas tsev ntawd paub tsag daim ntawv nws kuaj sau tseg, koj yeev quab yuam (subpoena) tau tus neeg kuaj xyuas tsev los mus tau tom tsev hais plaub. Nug tus pab tsev hais plaub ua ntaub ntawv quab yuam rau koj.
 - Koj koj tau neeg los ua tim khawv, li neeg nyob ze ua tau pom thiab paub txog cov teeb meem.

Rau ib qhov teeb meem, koj yuav tsum qhia tau:

- Teeb meem no tau tshwm sim ho ntev npaum li cas lawm.
- Ho puab tswag hnuv ua tus tswv tsev tau pom txog qhov teeb meem ntawd.
- Qhov teeb meem ntawd ho tshwm sim thiab ua tau tej yam txhawj siab li cas rau koj lawm. Hais ncauj lub kom ntxaws!



- Koj nug tau lub tsev hais plaub:
 - Txib kho vaj tsev.
 - Luv nqi xauj tsev txog hnuv ua kho tsev tiav lawm.
 - Muaj nyiaj them nqi xauj tsev thim rov qab rau cov hli ua muab tej teeb meem ntawd.
 - Cia koj nrho tawm ntawm koj li nqi xauj tsev los nrhiav kev kho rau cov teeb meem ntawd.

Piv txwv li:

Txog lub rau hli ntuj lawm. Koj tsiv los nyob thaum lub ib hli hnuv tim ib lawm. Cov kav dej twb tsis ua hauj lwm zoo thaum koj tsiv los nyob. Koj tau sau tsab ntawv qhia koj tus tswv tsev txog cov kav dej tsis hauj lwm zoo tam sim ntawd. Ru tsev twb xau dej thaum lub peb hli ntawd los lawm, thiab koj twb sau qhia koj tus tswv tsev thaum nws tshwm sim los.

Yog koj tsis tau them nqi xauj tsev rau lub rau hli no, koj siv tau qhov nyiaj them nqi rau lub rau hli los pib ua daim ntaub ntawv tiv thaib nqi xauj tsev nrog daim ntawv tom qab cov ntaub ntawv qhia no thiab nrog cov tsab ntawv es luam ua koj xav rau tus tswv tsev thaum lub ib hli thiab lub peb hli ntawd. Koj nug tau kom luv nqi rau lub ib hli thiab lub ob hli vim hais tias cov kav dej tsis ua hauj lwm zoo thiab luv kom ntau zog rau lub peb, plaub, tsib, thiab rau hli, vim hais tias ntxiv qhov teeb meem thib ob, lub ru tsev xau dej.

Yog li thaum, pob nyiaj ua koj them rau tim tsev hais plaub, ib qhov nyiaj ntawd yuav tsum thim rov qab rau koj vim hais tias cov teeb meem ntawd tsis tau mas kho. Tsis yog li thaum thiab, lawv yeev tsum luv koj cov nqi xauj tsev txog hnuv kho tiav tej teeb meem ua lub tsev hais plaub toob kas.

Ib qhov ua tseem ceeb es yuav tsum sau tseg yog hais tias tus kws txiav txim plaub yog tus neeg ua yuav luv tau koj qhov nqi xauj tsev. Txawv kws txiav txim plaub muab tau tus nqi txawv rau cov teeb meem ntawd ces yog li qhov nqi ua lawv yuav luv tej zaum yuav txawv deb thiab nyob ntawd leej twg yuav txiav txim los puab yog lub zos ua koj nyob.

Thov nco: Daim ntaub ntawv tiv thaib nqi xauj tsev tsuas yog los hais kom tus tswv tsev kho vaj tsev, tsis yog kom thim nqi xauj tsev rov qab. Vim li ntawd koj yuav tsum qhia kom tau ib qhov teeb meem dhau ib qhov thiab ua rau koj lub neej xauj tsev nyuab nyuab lawm yog ib qhov ua tseem ceeb. Qhia tau hais tias cov teeb meem ntawd ua rau koj lub neej nyuab npaum li cas rau tus kws txiav txim plaub kom pov thawj twb li pab hais tau luv nqi xauj tsev thiab txib kom tau kho vaj tsev.

Puas muab dab tsi ntxiv es koj ua tau?

Yog koj tsis ua daim ntaub ntawv tiv thaib nqi xauj tsev, koj foob tau hauv tsev hais plaub me (Conciliation Court) kom thim tau koj qhov nyiaj ua them xauj tsev. Koj ua tau yaj no thaum koj tseem nyob los puab yog tom qab koj tsiv tawm tsev.

Tom tsev hais plaub me, koj nug tsis tau kom tus tswv tsev kho vaj tsev – tsuag yog rau hais txog nyiaj. Koj tsis tas muab kws hais plaub. Hais txog ntawm ntaub ntawv pov thawj, siv tej yam li tsab ntawv, ntaub ntawv los ntawm tus neeg kuaj xyuas tsev, thiab duab. Saib peb li ntaub ntawv qhia, [Conciliation Court.](#) (lus Askiv xwb)



Nrhiav lwm yam Legal Aid Society ntaub ntawv, mus saib tos vas sab [www.lawhelpmn.org/LASMfactsheets.](http://www.lawhelpmn.org/LASMfactsheets)

Nrhiav hauv koj lub zos raws li txoj cai aid office ntawm www.lawhelpmn.org/resource/legal-aid-offices

Tsis txhob siv daim ntawv qhia no yog tias nws twb ua tawm los dhau ib xyoos lawm. Sau ntawv rau peb kom peb tau kho cov ntawv thiab muab hloov tshiab, daim ntawv qhia txhua yam uas muaj tiag nov, los yog lwm hom siv los qhia.

© 2018 Minnesota Legal Services Coalition. Cov ntaub ntawv no rov muab tsim tawm dua tau thiab siv rau tsis yog lag luam thiab kev kawm xwb. Tas nrho txoj cai tshwj tseg. Qhov lus ceeb toom no yuav tsum nyob ntawm txhua txhua daim ntawv luam. Txwv ncaj nraim tsis pub rov muab tsim tawm thiab faib rau suav daws yam yuav nyiaj ua lag luam.

TENANT'S REPAIR LIST – Request for Repairs
(Daim ntawv nug kho)

Dear/Rau _____

Date/Hnub Nos: _____

Please make the following repairs within the next 14 days.
 (Phov kho cov teeb meem nos, tsis pub dhau 14 hnub.)

√	PROBLEM (TEEB MEEM)	WHEN IT STARTED (HNUB UAS PIB)	DESCRIPTION (PIAV QHIA)
INFESTATIONS (MUAB KAB)			
	Mice (Nas)		
	Cockroaches (Kab laum)		
	Bed bugs (Kab nyob rau hauv txaj)		
	Other (Lwm yas)		
ELECTRICAL (HLUAV TAWS XOB)			
	No/ broken smoke detector (Tsis muab tswb nrov ceeb toom, los yog puas lawm)		
	Exposed Wiring (Pom txoj xov tooj)		
	Short Circuits (Txoj xov tooj sib txhuam)		
	No cover plates on outlets (Tsis muab lub khwb qhov fai fab)		
	Other (Lwm yas)		
PLUMBING (COV KAV DEJ)			
	No hot water (Tsis muab dej kub)		
	Clogged pipes/toilet (daig kav dej/ qhov viv)		
	Bad water pressure (Kav dej khiav tsis zoo)		
	Dripping faucets (Dej nrog ntawm kais dej)		
	Leaks (Dej xau)		
	Other (Lwm yas)		
WINDOWS (QHOV RAI)			
	Missing/torn screens (Tsis muab lub vas, los yog puas lawm)		
	Missing/torn storm windows (Tsis muab qhov rai rau qab daus, los yog puas lawm)		

√	PROBLEM (TEEB MEEM)	WHEN IT STARTED (HNUB UAS PIB)	DESCRIPTION (PIAV QHIA)
	Broken/cracked glass <i>(lav puas, los yog tawg lawm)</i>		
	Missing/ broken locks <i>(Tsis muab lub xauv, los yog puas lawm)</i>		
	Other <i>(Lwm yas)</i>		
DOORS (QHOV ROOJ)			
	No deadbolt locks <i>(Tsis muab lub ntsuas phoo)</i>		
	Broken locks <i>(Lub xauv puas lawm)</i>		
	Missing/broken door knobs <i>(Tsis muab pob qhov rooj, los yog puas lawm)</i>		
	Other <i>(Lwm yas)</i>		
WALLS / CEILINGS/ FLOORS (PHAB NTSA/ QAB NTHAB/ PEM TEB)			
	Chipped / flaking paint <i>(Xim tws ntoo)</i>		
	Holes or cracks in walls <i>(Phab ntsa muab qhov, los yog tawg pleb)</i>		
	Leaky roof or ceiling <i>(Qab nthab xau dej)</i>		
	Holes in carpet <i>(Ntaub pua pem teb muab qhov)</i>		
	Missing/broken tiles or linoleum <i>(Tsis muab pozeb pua pem teb, los yog tawg lawm)</i>		
	Other <i>(Lwm yas)</i>		
FURNACE (CUA SOV)			
	Not enough heat <i>(Cua sov tsis txaus)</i>		
	Gas leaks <i>(Roj xau)</i>		
	Other <i>(Lwm yas)</i>		
APPLIANCES (KHOOM SIV)			
	Broken stove/oven <i>(Qhov cub puas lawm)</i>		
	Broken refrigerator <i>(Tub yees puas lawm)</i>		
	Other <i>(Lwm yas)</i>		
SECURITY / PRIVACY (KEV RUAJ NTSEG/ KEV TSIS PUB LUAG TEJ PAUB)			
	Illegal entries by landlord <i>(Tswv tsev nkag tsev txhaum cai)</i>		
	Disturbance by other tenants <i>(Lwm tus neeg xauv tsev ua yam thab plaub)</i>		
	Break-ins, vandalism <i>(Neeg ua tus sab, los yog txhob txwm rhuav tsev)</i>		
	Other <i>(Lwm yas)</i>		

√	PROBLEM (TEEB MEEM)	WHEN IT STARTED (HNUB UAS PIB)	DESCRIPTION (PIAV QHIA)
OTHER AREAS (LWM QHOV CHAW)			
	Bare patches in yard (Nyom tsis tuaj)		
	Trash from previous tenant (Muab khib nyiab los ntawm tus neeg xauv yav dhau los)		
	Problem with garage (Teeb meem nrog lub chav nres tsheb)		
	Leaky basement (Dej xau qhab daus)		
	Pay utility bills (Them tej nuj nqi)		
	Other (Lwm yas)		

Tenant's Name:
(neeg xauj tsev lub npe) _____

Tenant's Address:
(neeg xauj tsev qhov chaw nyob) _____

Tenant's Signature:
(neeg xauj tsev kos npe) _____

STATE OF MINNESOTA

COUNTY OF _____ JUDICIAL DISTRICT _____

Plaintiff (tenant)

**RENT ESCROW
AFFIDAVIT**

vs.

FILE NO:

Defendant (Landlord)

Plaintiff states under oath:

1) My address is _____

2) My landlord's name is _____

3) My landlord's address is _____

4) The monthly rent is \$ _____

- 5) I sent the landlord a written notice describing the repair problems or violations of the lease. The landlord did not fix them within 14 days. A copy of my written communication to my landlord is attached.
- and / or
- An inspector ordered the landlord to make repairs. The inspector's deadline has passed, and the landlord has not made all the repairs. A copy of the inspector's orders is attached.

6) As of today, the amount of rent that I owe is \$ _____ I am depositing that amount with the court.

7) My best estimate is that it would cost \$ _____ for the landlord to make all the repairs.

8) The landlord has known about these repair problems since approximately the following date or dates _____

9) Since these repair problems have existed, my apartment has not been worth the amount of rent I pay. It has only been worth \$ _____ per month.

- 10) I respectfully ask the court to issue an order including the following:
 - a. Order the landlord to make all of the repairs right away.

- b. Reduce my rent to \$ _____ per month until the month after all of the repairs are completed. For any repairs that the landlord does not complete by the Court's deadline, authorize me to pay for the repairs myself and deduct the payments from future rent.
- c. Of the money I deposited with the court, order that \$ _____ be returned to me, for the rent that I have paid while the landlord did not make the repairs.
- d. If I am entitled to more rent money back for the repair problems in the past months, enter a judgment against the landlord for \$ _____ and authorize me to collect the judgment by taking it out of future months' rent.
- e. If I have used an attorney, enter a judgment in my favor for reasonable attorney fees. Authorize me to collect the judgment by taking it out of future months' rent.
- f. Set a follow-up hearing to make sure the landlord has made the repairs ordered.
- g. Other: _____

11) To the best of my knowledge, I am not filing this case for an improper reason, such as harassment or delay; my claims are supported by the law, and there is evidence for them. I know that I can be fined or sanctioned by the court if this statement is false.

I declare under penalty of perjury that everything I have stated in this document is true and correct.

Dated: _____

Signature

Name: _____

Address: _____

City, State, Zip: _____

Phone: _____

E-mail: _____

For the court to fill out

Total rent deposited: \$ _____ + \$16.00 filing fee = \$ _____ total paid.

Set for _____ at ___ M, in _____ Notice sent _____

Continued to _____ at ___ M, in _____ Notice sent _____